

LEOMI[®]
— OPTIMIZING LIFE —

$$q=h\Delta T$$

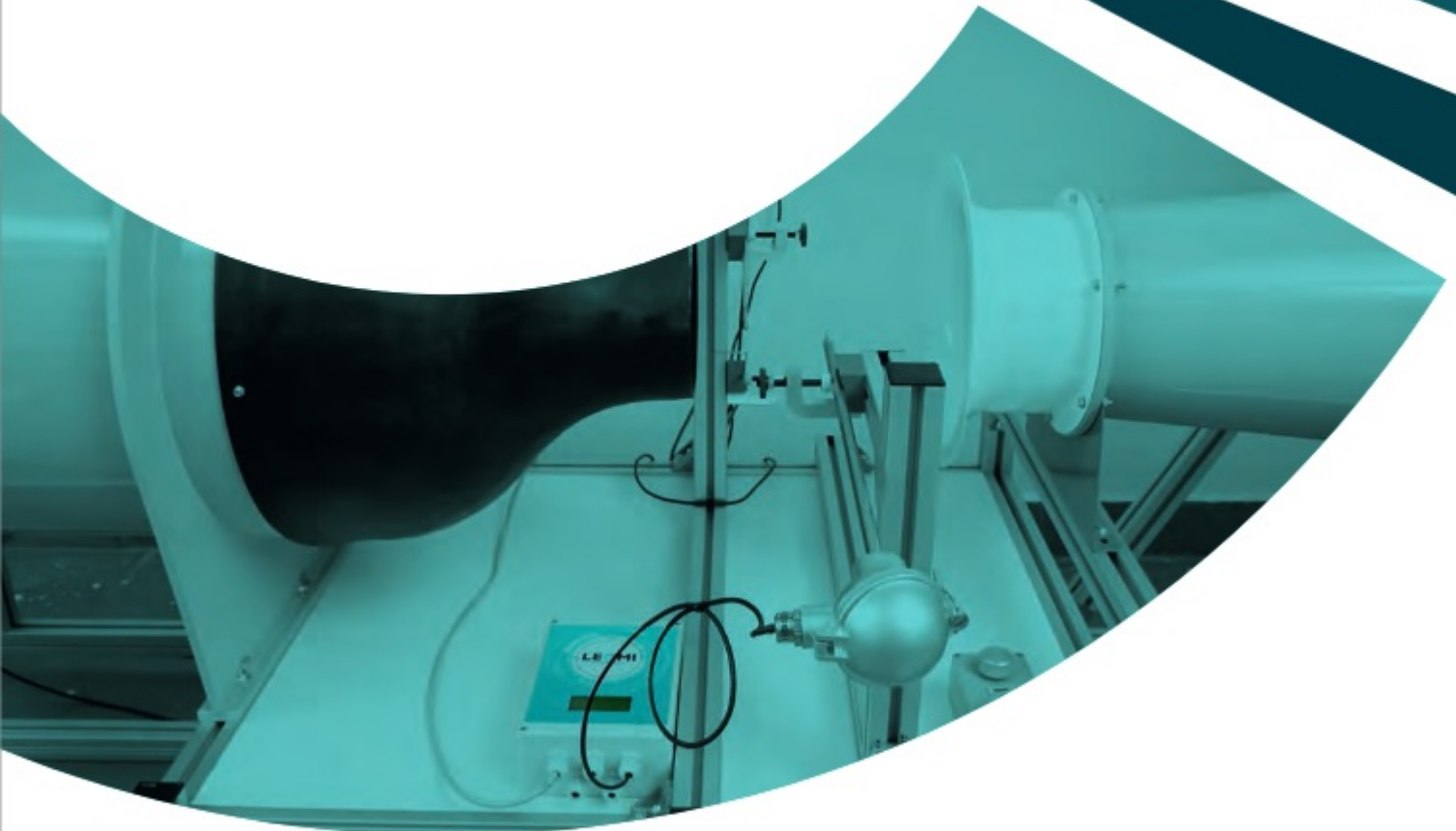

Manufacturer of Insertion Thermal Mass
Flowmeter for Compressed Air & Process Gases

GERMAN TECHNOLOGY ENGINEERED IN INDIA

ABOUT US

A continuous endeavour of more than two decades into the field of technologies and automation has inspired LEOMI Founders to start a manufacturing venture looking into the industrial measurement solutions that optimizes life. LEOMI provides affordable and reliable solutions with the hands on expertise of MTS Engineers Pvt Ltd that has fuelled reputed companies for industry specific technologies. LEOMI strive to hunt industries' rugged applications for optimization of industrial processes with German technology transfer from growth engine of India, Gujarat.

MISSION



Developing measurement instruments to optimize life of industrial processes & equipments

INTEGRITY



We embrace values of our stakeholders by remaining transparent and ethical in our dealings

PRACTICAL



We understand and adaptive to real situations of our stakeholders for our business actions

RESPONSIBLE



We responsibly conduct business considering socio-economic needs

HOLISTIC



We accept holistic approaches in collaboration with our stakeholders for betterment of humanity

INNOVATIVE



Our team engages in providing innovative solutions by working upon customer's pain areas consciously

OPTIMIZING LIFE OF PROCESS, MACHINE AND EQUIPMENT

ABOUT US

- Started manufacturing at Electronic GIDC Gandhinagar, India in the year 2018 with more than 10000 sq ft 3 floor premises.
- An ISO 9001:2015 & Start-up India registered company.
- "Optimizing Life" is a central idea for new product & solutions development helping process optimization & control.
- Developing Thermal Mass Flowmeter in technical collaboration with Softflow.de Germany, product proven field performance more than 20 years, now produced at Leomi India.
- Highly experienced promoters & trained technical staff for production, testing, calibration and R&D.
- In-house product quality testing & proprietary calibration system with latest renowned brand test equipment in place.
- Installed India's First state-of-art Fully Automatic Wind Tunnel Made in Germany traceable to ISO-17025 standards.



TECHNOLOGY VERIFICATION INITIATIVE

Thermal Dispersion technology for gas mass flow monitoring is emerging as economical, robust, and accurate against conventional differential pressure-based flow measurement. Due to continuous research and development, Leomi's technical team has gain in-depth knowledge for developing customized flow sensor with a combination of different materials and/or coatings for challenging process applications. Leomi team is ready to join hands to work on special projects together with customers for their applications success. Let's work together for your challenging application together for process optimization.



CERTIFICATIONS



#startupindia



CALIBRATION

CALIBRATION FACILITY

India's first In-house latest state-of-the-art made in Germany fully automatic Göttinger calibration wind tunnel DKD certified as per ISO-17025 DAkkS traceability for Air Velocity ranges 0.2 m/s to 75 m/s with flow uniformity of $\pm 0.2\%$.

CALIBRATION SERVICES

LEOMI provides calibration services for other manufacturers of various types of Air velocity Instruments such as Insertion Thermal Mass Flowmeter, Hot-wire & Vane Anemometer, Pitot Tubes etc.



MEASUREMENT PRINCIPLE

THERMAL DISPERSION TECHNIQUE

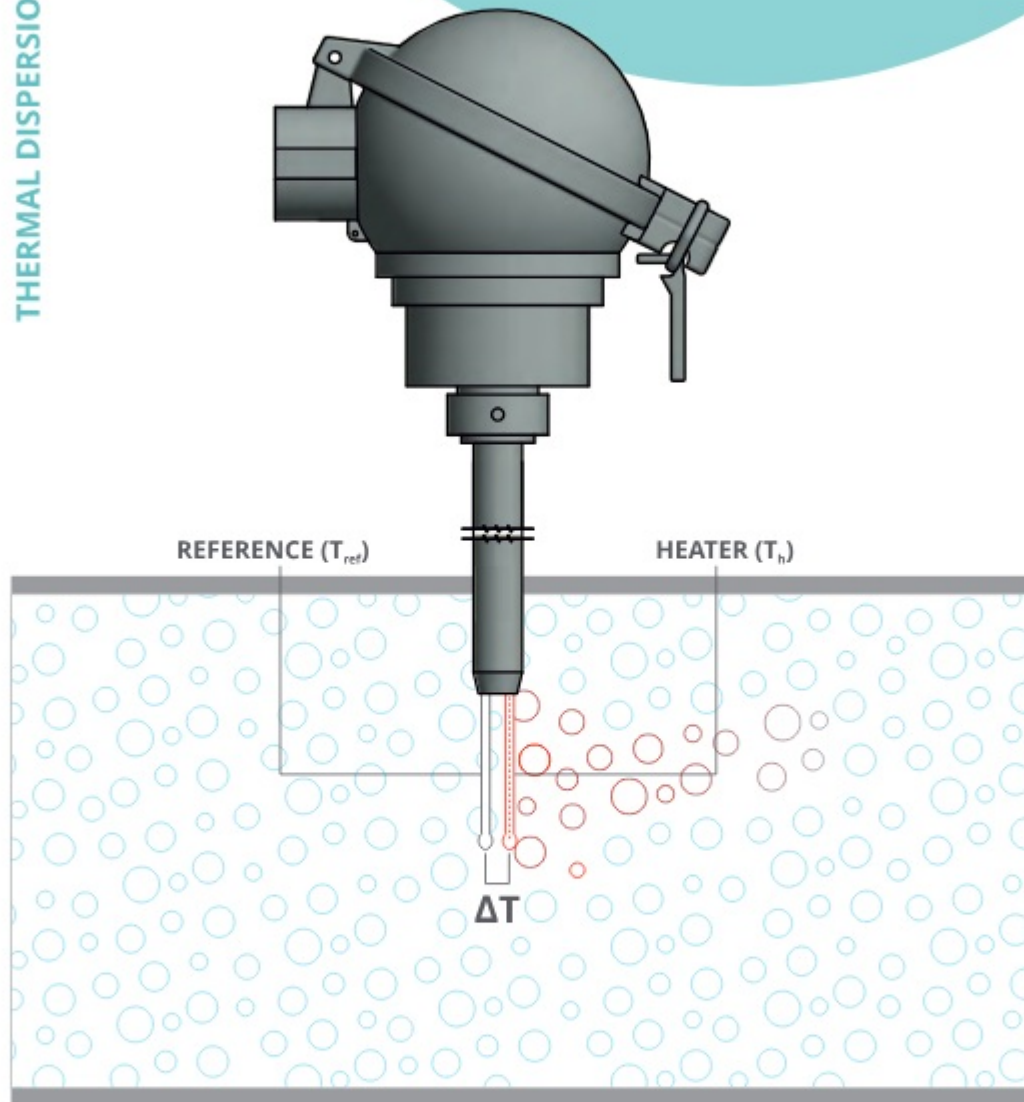

Constant Temperature Anemometry (CTA)

(Digital controlled Circuit not Wheatstone bridge)

LEOMI Thermal Mass (Calorimetric) Flow Meter works on the physical principle of thermal dispersion from a heated element to the ambient medium (example: air or gases). This is affected by the velocity, density (temperature and pressure) and by the characteristic of the medium. The amount of needed energy is a function of the temperature difference ΔT and the mass flow.

Gas flowing through two RTD Pt-100 one reference (T_{ref}) and other Heater (T_h). The temperature difference (over-temperature) Δt between the reference sensor (medium temperature) and the heater sensor is controlled constantly. As per **King's Law**, higher the mass flow rate, higher the cooling effect of the heater sensor, thus higher the power required to maintain the differential temperature constant. Therefore the heater power is proportional to the gas mass flow rate.

LEOMI 586

Standard Mass / Volume flowmeter



SS 316Ti / Hastelloy C276
without Safety Head



SS 316Ti with
Safety Head



HALAR® Coated



PFA Coated

FEATURES

- No moving parts
- Wide measuring ranges allow the detection of leakage & increases in consumption
- Measuring mass flow rate independent of pressure and temperature variations
- High accuracy throughout temperature ranges up to 400°C
- Operates in any positions
- Customized Sensor probe material in different diameters possible based on application
- Programmable pipe diameters from 15mm to 10000mm
- Circular, Square, Rectangular and other ducts mounting possible
- Easy Installation & maintenance
- HALAR® & PFA coated probes for highly corrosive gases available
- Integration in data network with different data converters possible
- In-built terminal software with gas volume, gas mixture & insertion depth calculators

SENSOR TECHNICAL SPECIFICATION

Sensor Details	: 2 X Pt-100 RTD Sensor Element (4-wire Technique) Diameter : 12mm (Std), 20mm, 25mm (Optional) Length : 250mm; 500mm; 1000mm (Other upon request)
Sensor Material	SS-316Ti DIN1.4571/ Hastelloy C276; HALAR® & PFA Coating for corrosive gases (optional) (Other consult factory)
Fluids	Air & Gases
Flow Range	: 0.6 – 65 Nm/s (Turndown 100:1); 0.6 -150 Nm/s (optional) (N stands for DIN 1343: 0°C/1.01325 bar(a), 0% RH)
Accuracy (%)*	: ±1.5% reading (-40°C-100°C); ±2.0% reading (0°C -200°C/ 300°C/ 400°C) for >=5m/s; +/- 0.1m/s. or better below 5m/s velocity at reference calibration conditions upto 75 m/s. (**Better accuracy possible please consult factory)
Repeatability (%)	: ±0.5% of reading
Response time t90	: <1.5secs
Operating temperature	: -40°C to +100°C, 0 - 200°C; 0 -300°C; 0 - 400°C
Operating pressure	: 16bar(g) Max. PN16 (Higher upon request)
Ambient temperature	: -40°C to +80°C
Process connection	: SS-316 Compression ferrule fitting for probe: ½" NPT(M) & ¾" NPT(M) (Other upon request)
Ingress Protection	: IP67 (NEMA 6)

* Calorimetric flow sensors normally needed no service, but however, electronic components get under influence of growing older and changing its electrical characteristics. Changing of the coating by corrosion and pollution could also influence the accuracy. So, it is necessary, from time to time (recommendation: about every 2 years) to check the calibration.

** Better accuracy with additional charges possible.



Note: Technical specifications and dimensions subject to change due to continuous research and development.

SIGNAL TRANSMITTER TECHNICAL SPECIFICATIONS

LEOMI 586

Remote Signal Transmitter	: Microprocessor based, complete and automatic compensation of temperature conditioned signal drifting. Digital conductivity compensated adjustment of the heater over temperature
Power Supply	: 24VDC (18 - 36VDC) OR 100 – 265 VAC@50Hz
Power Consumption	: < 5 watts
Display	: 16 X 4 LCD Backlit Display
Measuring Unit	: Mass Flowrate (Kg/hr) Totalizer (Kg); Volume flowrate (Nm3/Hr or SCFM) & Totalizer (Nm3 or SCF) & Process Temperature(°C)
Outputs	: 0/4-20 mADC (Isolated 600Ω) OR 0 -10VDC flowrate proportional; 1 NO/ NC Relay contact @250VAC/ 6A programmable for Temperature OR Flowrate; Opto-coupler impulse output, RS-232 Modbus Bi-directional for data transmission & configuration via LEOMI 580.1.0.0 Terminal Software (other data converters available on request)
Ambient Temperature	: -20°C to +60°C
Ingress Protection	: IP 65/ IP 66 (NEMA 4X) OR IP 67 (NEMA 6) (Optional)
Testing standards	: EMC/EMI compliant as per IEC 61000 as per CE norms
Enclosure Details	: ABS Plastic 200mm(L)x150mm(W) x79mm(D); Aluminium Diecast (Optional) 260mm (L) x 160mm(W) x 91mm (D) (Other upon request)

MODEL CODE LEOMI 586

Part No. 0500 0586 S 2 3 Y A 1 1 R 2 C 1 M 5

1	Probe MOC	S	SS 316 Ti (1.4571)
		C	Hastelloy C276 (2.4819)
		H	SS 316 Ti (1.4571) with HALAR® Coating - Upto 75°C
		P	SS 316 Ti (1.4571) with PFA Coating - Upto 175°C
2	Length	2	250 mm
		5	500 mm
		8	1000 mm
		9	Other (Please Specify)
3	Temperature	1	100°C
		2	200°C
		3	300°C
		4	400°C
4	Probe Sensor Protection	N	Without Safety Head
		Y	With Safety Head (only for SS316 Probe MOC)
5	Probe Head Junction Box MOC	A	Aluminium Die Cast
		9	Other (Please Specify)
6	Probe Connection	1	SS 316 Compression Ferrule - 1/2" NPT (M) for SS-316 or 3/4" NPT (M) for Hastelloy C276 Probe MOC
		9	Other (Please Specify)
7	Cable	1	5 Mtrs
		2	10 Mtrs
		3	20 Mtrs
		4	30 Mtrs
		9	Other (Please Specify)
8	Transmitter	R	Remote
9	Input Power Supply	1	24 VDC
		2	100 - 265 VAC@50Hz
10	Output 1	C	4-20 mA DC (Isolated@600Ω)
		V	0-10 VDC
		H	HART Compatible 4-20 mA DC
11	Output 2	1	Relay Output or Pulse Output
12	Communication Interface	N	Not Applicable*
		M	RS 485 Modbus RTU
		9	Other (Please Specify)
13	Enclosure MOC	5	ABS Plastic - IP 65
		6	Aluminium Die Cast - IP 66
		7	Aluminium Die Cast - IP 67
		9	Other (Please Specify)

* RS-232 Modbus Bi-directional for data transmission & configuration via LEOMI 586 1.0.0 Terminal Software is by default.

APPLICATIONS

TEXTILE INDUSTRY



Compressed Air, Combustion Air,
Natural Gas, Aeration Air

CEMENT & FERTILIZERS



Process Gas, Co₂ Gas, Compressed Air, Natural Gas, Combustion Air, Flue Gas, Aeration Air

CHEMICAL & PETROCHEMICALS



Flare Gas, Process Gas, Compressed Air, Natural Gas, Combustion Air, Aeration Air

STEEL & POWER



Fluegas, Blast Furnace Gas, Combustion Air, Compressed Air, Natural Gas, Welding Gas

AUTOMOBILE & ANCILLARIES



Natural Gas, Compressed Air, Welding Gases

FOOD & PHARMACEUTICALS



Aeration Air, Biogas, Compressed Air, Natural Gas,

No Pressure Drop

High Turndown Ratio

Accurate measurement over temperature ranges upto 400°C

Works well even in Wet Gas Applications

SOFTWARE & CALCULATORS



Leomi Terminal Software Version 580.1.0.0



Leomi Software 587.1.0.0



Sensor surface insertion depth calculator



Gas volume (flow rate) calculator



Gas mixture calculator

ACCESSORIES



Ball Valve



Flange Accessories



Compression Ferrule



Retractable Assembly

MAJOR CUSTOMERS

**AM/NS
INDIA**



OUR PRESENCE





58016.0.0

LEOMI INSTRUMENTS PVT. LTD.

E-17/5, Electronic GIDC, Sector-26,
Gandhinagar-382027, Gujarat, INDIA.

☎ +91 79 23287899, +91 90547 50586

✉ sales@leomi.in 🌐 www.leomi.in