

LEOMI[®]
— OPTIMIZING LIFE —

$$q=h\Delta T$$

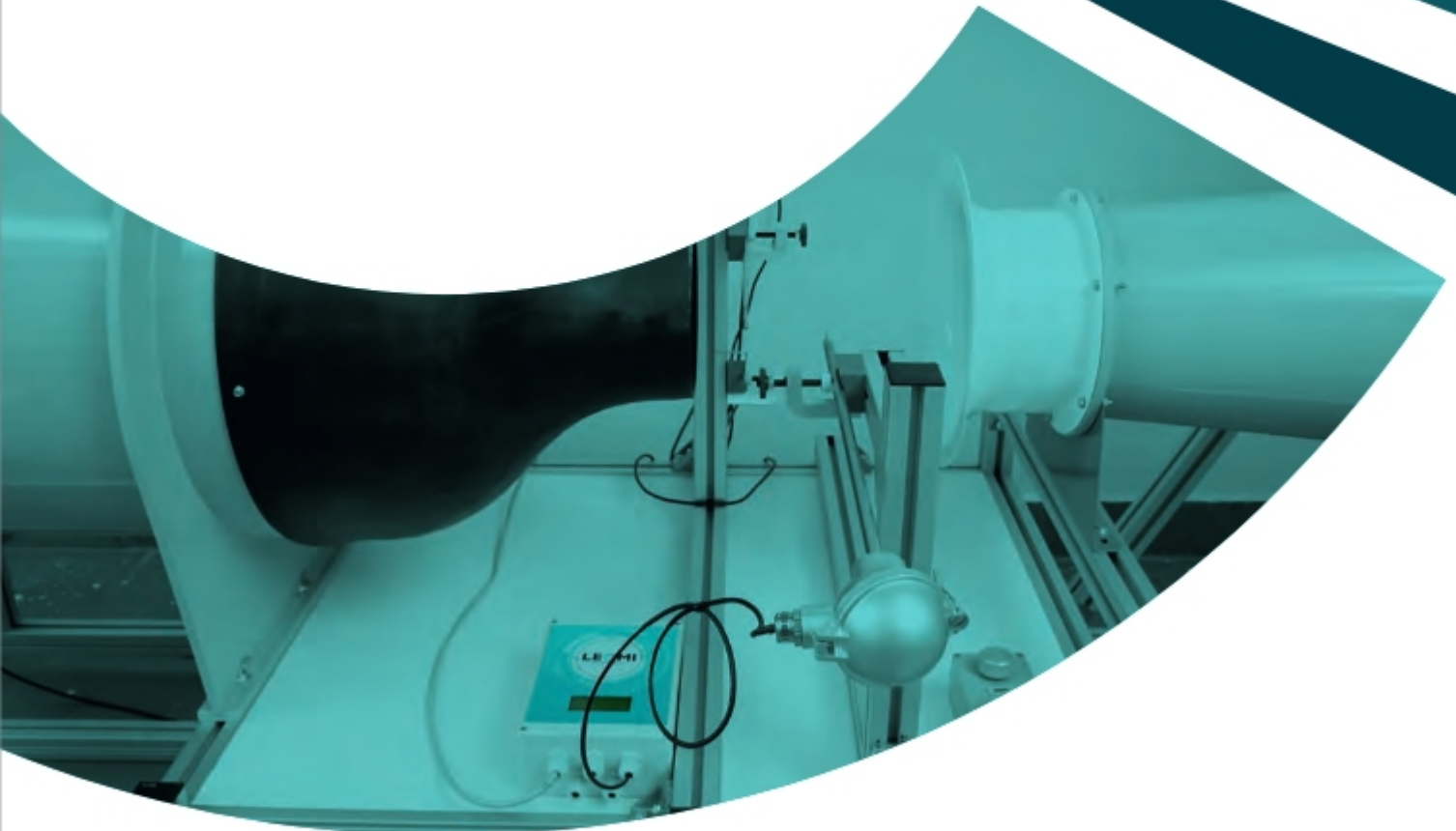

Manufacturer of Insertion Thermal Mass
Flowmeter for Compressed Air & Process Gases

GERMAN TECHNOLOGY ENGINEERED IN INDIA

ABOUT US

A continuous endeavour of more than two decades into the field of technologies and automation has inspired LEOMI Founders to start a manufacturing venture looking into the industrial measurement solutions that optimizes life. LEOMI provides affordable and reliable solutions with the hands on expertise of MTS Engineers Pvt Ltd that has fuelled reputed companies for industry specific technologies. LEOMI strive to hunt industries' rugged applications for optimization of industrial processes with German technology transfer from growth engine of India, Gujarat.

MISSION



Developing measurement instruments to optimize life of industrial processes & equipments

INTEGRITY



We embrace values of our stakeholders by remaining transparent and ethical in our dealings

PRACTICAL



We understand and adaptive to real situations of our stakeholders for our business actions

RESPONSIBLE



We responsibly conduct business considering socio-economic needs

HOLISTIC



We accept holistic approaches in collaboration with our stakeholders for betterment of humanity

INNOVATIVE



Our team engages in providing innovative solutions by working upon customer's pain areas consciously

OPTIMIZING LIFE OF PROCESS, MACHINE AND EQUIPMENT

ABOUT US

- Started manufacturing at Electronic GIDC Gandhinagar, India in the year 2018 with more than 10000 sq ft 3 floor premises.
- An ISO 9001:2015 & Start-up India registered company.
- "Optimizing Life" is a central idea for new product & solutions development helping process optimization & control.
- Developing Thermal Mass Flowmeter in technical collaboration with Softflow.de Germany, product proven field performance more than 20 years, now produced at Leomi India.
- Highly experienced promoters & trained technical staff for production, testing, calibration and R&D.
- In-house product quality testing & proprietary calibration system with latest renowned brand test equipment in place.
- Installed India's First state-of-art Fully Automatic Wind Tunnel Made in Germany traceable to ISO-17025 standards.



TECHNOLOGY VERIFICATION INITIATIVE

Thermal Dispersion technology for gas mass flow monitoring is emerging as economical, robust, and accurate against conventional differential pressure-based flow measurement. Due to continuous research and development, Leomi's technical team has gain in-depth knowledge for developing customized flow sensor with a combination of different materials and/or coatings for challenging process applications. Leomi team is ready to join hands to work on special projects together with customers for their applications success. Let's work together for your challenging application together for process optimization.



CERTIFICATIONS



#startupindia



CALIBRATION

CALIBRATION FACILITY

India's first In-house latest state-of-the-art made in Germany fully automatic Göttinger calibration wind tunnel DKD certified as per ISO-17025 DAkkS traceability for Air Velocity ranges 0.2 m/s to 75 m/s with flow uniformity of $\pm 0.2\%$.

CALIBRATION SERVICES

LEOMI provides calibration services for other manufacturers of various types of Air velocity Instruments such as Insertion Thermal Mass Flowmeter, Hot-wire & Vane Anemometer, Pitot Tubes etc.



MEASUREMENT PRINCIPLE

THERMAL DISPERSION TECHNIQUE

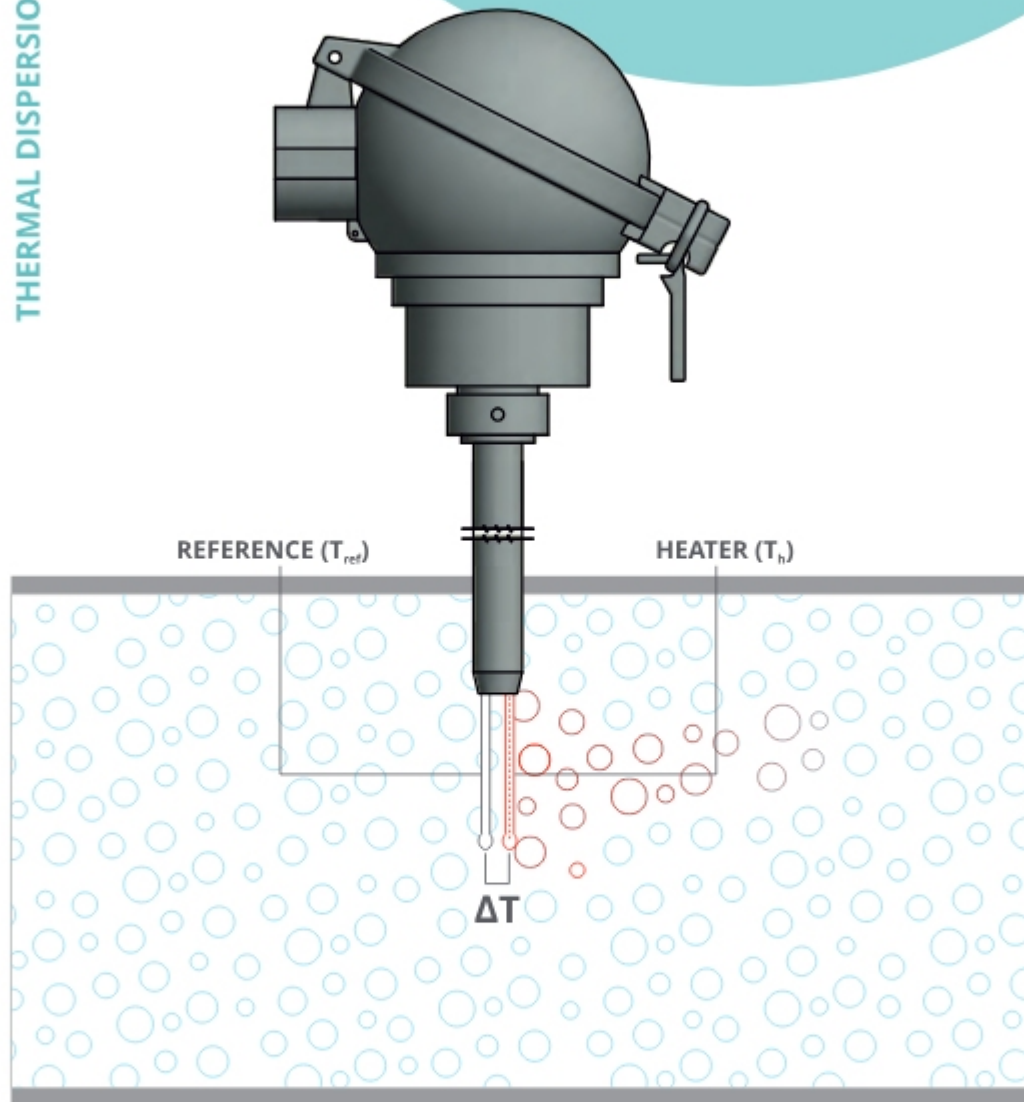

Constant Temperature Anemometry (CTA)

(Digital controlled Circuit not Wheatstone bridge)

LEOMI Thermal Mass (Calorimetric) Flow Meter works on the physical principle of thermal dispersion from a heated element to the ambient medium (example: air or gases). This is affected by the velocity, density (temperature and pressure) and by the characteristic of the medium. The amount of needed energy is a function of the temperature difference ΔT and the mass flow.

Gas flowing through two RTD Pt-100 one reference (T_{ref}) and other Heater (T_h). The temperature difference (over-temperature) Δt between the reference sensor (medium temperature) and the heater sensor is controlled constantly. As per **King's Law**, higher the mass flow rate, higher the cooling effect of the heater sensor, thus higher the power required to maintain the differential temperature constant. Therefore the heater power is proportional to the gas mass flow rate.

LEOMI 587

Actual Mass/ Volume flowmeter



SS 316Ti / Hastelloy C276
without Safety Head



SS 316Ti with
Safety Head



HALAR® Coated



PFA Coated

FEATURES

- Measuring actual mass/volume flow rate
- Suitable to 15mm to 10000mm pipe sizes
- Probes with $\varnothing=12\text{mm}/20\text{mm}(\text{HC276})$ & Length up-to 2000 mm available
- Better accuracy $< \pm 2\% \text{RD}$ of actual mass flow rate
- Upto 4 user selectable analogue input such as pressure, temperature, power or RH% etc.
- Turndown ratio 100:1 or better
- Accurate measurement over temperature ranges upto 400°C
- In-built data storage with USB 2.0 in csv format for input parameters
- In-built auto purging system for sensor cleaning
- Ideal for customized flow control applications with PC software

SENSOR TECHNICAL SPECIFICATION

Sensor Details	: 2 X Pt-100 RTD Sensor Element (4-wire Technique) Diameter :12mm(Std), 20mm, 25mm (Optional) Length : 250mm; 500mm; 1000mm (Other upon request)
Sensor Material	SS-316Ti DIN1.4571/ Hastelloy C276; HALAR® & PFA Coating for corrosive gases (optional) (Other consult factory)
Fluids	Air & Gases
Flow Range	: 0.6 – 65 Nm/s (Turndown 100:1); 0.6 -150 Nm/s (optional) (N stands for DIN 1343: 0°C/1.01325 bar(a), 0% RH)
Accuracy (%)*	: ±1.5% reading (-40°C-100°C); ±2.0% reading (0°C -200°C/ 300°C/ 400°C) for >=5m/s; +/- 0.1m/s. or better below 5m/s velocity at reference calibration conditions upto 75m/s. (** Better accuracy possible please consult factory)
Repeatability (%)	: ±0.5% of reading
Response time t90	: <3 secs
Operating temperature	: -40°C to +100°C, 0 - 200°C; 0 - 300°C; 0 - 400°C
Operating pressure	: 16bar(g) Max. PN16 (Higher upon request)
Ambient temperature	: -40°C to +80°C
Process connection	: SS-316 Compression ferrule fitting for probe: ½" NPT(M) & ¾" NPT(M) (Other upon request)
Ingress Protection	: IP67 (NEMA 6)

* Calorimetric flow sensors normally needed no service, but however, electronic components get under influence of growing older and changing its electrical characteristics. Changing of the coating by corrosion and pollution could also influence the accuracy. So, it is necessary, from time to time (recommendation: about every 2 years) to check the calibration.

** Better accuracy with additional charges possible.



Note: Technical specifications and dimensions subject to change due to continuous research and development.

SIGNAL TRANSMITTER TECHNICAL SPECIFICATIONS

LEOMI 587

Remote Signal Transmitter	: Microprocessor based, calculates operating mass or volume flow rate with additional inputs of pressure and/or temperature. Customised analogue & digital inputs/outputs
Power Supply	: 24VDC (18 - 36VDC) OR 100 – 265 VAC@50Hz
Power Consumption	: < 10 watts
Display	: 16 X 4 LCD Backlit Display
Measuring Unit	: Mass Flowrate (Kg/hr) Totalizer (Kg); Volume flowrate (m3/Hr or CFM) & Totalizer (m3 or CF) & Process Temperature(°C)
Outputs	: 0/4-20 mADC (Isolated 600Ω) OR 0 -10VDC flowrate proportional; 2 NO/ NC Relay contact @250VAC/ 6A programmable for Temperature OR Flowrate; Opto-coupler impulse output, RS485 Modbus RTU protocol with LEOMI 587.1.0.0 configuration software (other data converters available on request)
Ambient Temperature	: -20°C to +60°C
Inbuilt Storage	: In-built data storage with USB 2.0 in csv format for input parameters
Ingress Protection	: IP 65/ IP 66 (NEMA 4X) OR IP 67 (NEMA 6) (Optional)
Testing standards	: EMC/EMI compliant as per IEC 61000 as per CE norms
Enclosure Details	: ABS Plastic, 200mm(L) x150mm(W) x79mm(D); Aluminium Diecast (Optional) 260mm (L) x 160mm(W) x 91mm (D) (Other upon request)

MODEL CODE LEOMI 587

Part No.	S	2	3	Y	A	1	1	R	1	2	C	1	M	5
0500 0587														

1	Probe MOC	S	SS 316 Ti (1.4571)
		C	Hastelloy C276 (2.4819)
		H	SS 316 Ti (1.4571) with HALAR® Coating – Upto 75°C
		P	SS 316 Ti (1.4571) with PFA Coating - Upto 175°C
2	Length	2	250 mm
		5	500 mm
		8	1000 mm
		9	Other (Please Specify)
3	Temperature	1	100°C
		2	200°C
		3	300°C
		4	400°C
4	Probe Sensor Protection	N	Without Safety Head
		Y	With Safety Head (only for SS316 Probe MOC)
5	Probe Head Junction Box MOC	A	Aluminium Die Cast
		9	Other (Please Specify)
6	Probe Connection	1	SS 316 Compression Ferrule – 1/2" NPT (M) for SS-316 or 3/4" NPT (M) for Hastelloy C276 Probe MOC
		9	Other (Please Specify)
7	Cable	1	5 Mtrs
		2	10 Mtrs
		3	20 Mtrs
		4	30 Mtrs
		9	Other (Please Specify)
8	Transmitter	R	Remote
9	Input Power Supply	1	24 VDC
		2	100 - 265 VAC@50Hz
10	Input	2	4-20 mA – 2 Channel
		3	4-20 mA – 3 Channel
		4	4-20 mA – 4 Channel
11	Output 1	C	4-20 mA DC (Isolated@600Ω)
		V	0-10 VDC / 0-5 VDC
12	Output 2	1	Relay Output – 2 No.
13	Communication Interface	M	RS 485 Modbus RTU
		9	Other (Please Specify)
14	Enclosure MOC	5	ABS Plastic – IP 65
		6	Aluminium Die Cast – IP 66
		7	Aluminium Die Cast – IP 67
		9	Other (Please Specify)

APPLICATIONS

TEXTILE INDUSTRY



Compressed Air, Combustion Air,
Natural Gas, Aeration Air

CEMENT & FERTILIZERS



Process Gas, Co₂ Gas, Compressed Air, Natural Gas, Combustion Air, Flue Gas, Aeration Air

CHEMICAL & PETROCHEMICALS



Flare Gas, Process Gas, Compressed Air, Natural Gas, Combustion Air, Aeration Air

STEEL & POWER



Fluegas, Blast Furnace Gas, Combustion Air, Compressed Air, Natural Gas, Welding Gas

AUTOMOBILE & ANCILLARIES



Natural Gas, Compressed Air, Welding Gases

FOOD & PHARMACEUTICALS



Aeration Air, Biogas, Compressed Air, Natural Gas,

No Pressure Drop

High Turndown Ratio

Accurate measurement over temperature ranges upto 400°C

Works well even in Wet Gas Applications

SOFTWARE & CALCULATORS



Leomi Terminal Software Version 580.1.0.0



Leomi Software 587.1.0.0



Sensor surface insertion depth calculator



Gas volume (flow rate) calculator



Gas mixture calculator

ACCESSORIES



Ball Valve



Flange Accessories



Compression Ferrule



Retractable Assembly

MAJOR CUSTOMERS



OUR PRESENCE





58016.0.0

LEOMI INSTRUMENTS PVT. LTD.

E-17/5, Electronic GIDC, Sector-26,
Gandhinagar-382027, Gujarat, INDIA.

☎ +91 79 23287899, +91 90547 50586

✉ sales@leomi.in 🌐 www.leomi.in